

<h1>Malibu LED</h1>	Project Name:	Catalog Number:	Type
---------------------	---------------	-----------------	------

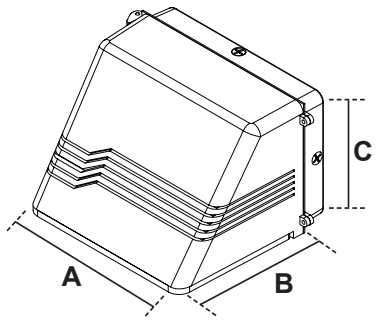

Dimensional Drawings



Fixture	A	B	C	Max. LEDs	Lbs
MLB-2	17"	14"	9"	48	29

The **Malibu** wall sconce is a low-profile, designer luminaire that provides excellent, uniform illumination with Dark-Sky approved, full-cutoff optics.

Lens: Each LED is covered with an injection-molded acrylic lens that provides a unique Type III distribution pattern.

Housing: The trapezoidal **Malibu** is of one-piece, precision die cast aluminum, constructed in a pleasing architectural design with decorative reveals. It features a one-piece, die cast aluminum, hinged door frame.

Finish: Durable Quali-Guard® textured thermoset polyester powder coat, oven-baked at a temperature of 400 °F to promote maximum adherence

and finish hardness. Finish is guaranteed for five (5) years.

Optics: The **Malibu** comes in a Type I or Type III distribution pattern and utilizes high lumen output LEDs.

LEDs: High lumen output VisionBar™ LEDs are utilized, offering a minimum estimated life of 60,000 hours in the desirable light color temperature of 4,000 Kelvin.

Driver: A high-performance electronic LED driver operates at 120 thru 277 volts, 50 to 60 Hz, with a 90% power factor; and is rated for -40 °C operation.

Model	Optics	Source	Milliamps	Kelvin	Voltage	Mounting	Finish	Options
MLB-2	Type I (T1) 	# of LEDs 24 (24L)	mA 350 (3)	4000K (4K)	120-277 *Universal voltage (UNV)	Wall Mount *Down light only (WM)	Bronze (BZ)	Button Type Photocell *Specify voltage (PC120) (PC208) (PC240) (PC277)
	Type III (T3) 	48 (48L)	530 (5)				White (WH) Silver Metallic (SL)	Vandal-Resistant Hardware *Tamper-proof latch screw. (VRH)

LED Data Chart

# Bars	# LEDs	Output mA	Initial Lumens T3	System Watts 120-277	L ₇₀ Hours @ 25° C
1	24	350	2,183	28	150,000
		530	2,693	38	100,000
2	48	350	4,366	56	150,000
		530	5,386	76	100,000

Visit www.VisionaireLighting.com for up-to-the-minute chart information, including types not listed here.

For more detailed information on mounting, wiring or installation instructions, please consult factory. If poles are not ordered with fixtures, please specify mounting requirements. This document contains proprietary information of Visionaire Lighting LLC. Any use of this information requires the written approval of Visionaire Lighting, LLC. In keeping with our TQM policy of continuous improvement, Visionaire reserves the right to change any specifications contained herein without prior notice.

